

**RACK MOUNT TYPE
8 CHANNEL V-F CONVERTER
(TYPE: VF8-01Z)
USER'S MANUAL**

4482 (Rev1/2024.12.06)



TSUJICON

APPLICATION OF ELECTRONIC DEVICES

TSUJI ELECTRONICS CO.,LTD

3739 Kandatsu-machi Tsuchiura-city
Ibaraki-Pre 300-0013 Japan
Phone +81-(0)29-832-3031
Fax +81-(0)29-832-2662
URL <http://www.tsujicon.jp>
E-mail info2@tsuji-denshi.co.jp

RACK MOUNT TYPE

8 CHANNEL V-F CONVERTER USER'S MANUAL

(TYPE: VF8-01Z)

VF8-01Z is constructed in a EIA 2 unit rack mount case.

VF8-01Z has eight channels outputs include a four stage amplification factor switch and a polarity selector switch.

In addition, with over range and polarity displayed, V-F conversion is always performed at the optimum conditions.

1. Specification

- | | | |
|------------------------------|---|--|
| 1) Gain | : | 10V, 1V, 100mV, 10mV |
| 2) Input Voltage | : | 0 ~ 10V (Acceptable input $\pm 100V$ Max) |
| 3) Input Resistance | : | 1M Ω or more |
| 4) Output | : | TTL level, Positive Logic, Pulse Width 100ns or more |
| 5) Output Frequency | : | 0 ~ 1MHz |
| 6) Conversion Accuracy | : | 0.05%FS |
| 7) Scale Over | : | Open collector transistor = ON (Insulation) |
| 8) Input / Case Isolation | : | Select either Isolation or GND |
| 9) Analog Monitor Output | : | Monitor analog value before V-F conversion |
| 10) Input / Output Connector | : | Isolated BNC |
| 11) Power Supply | : | AC100V |
| 12) Case | : | EIA 2 unit W482xD430xH88mm |

2. Front Panel / Rear Panel

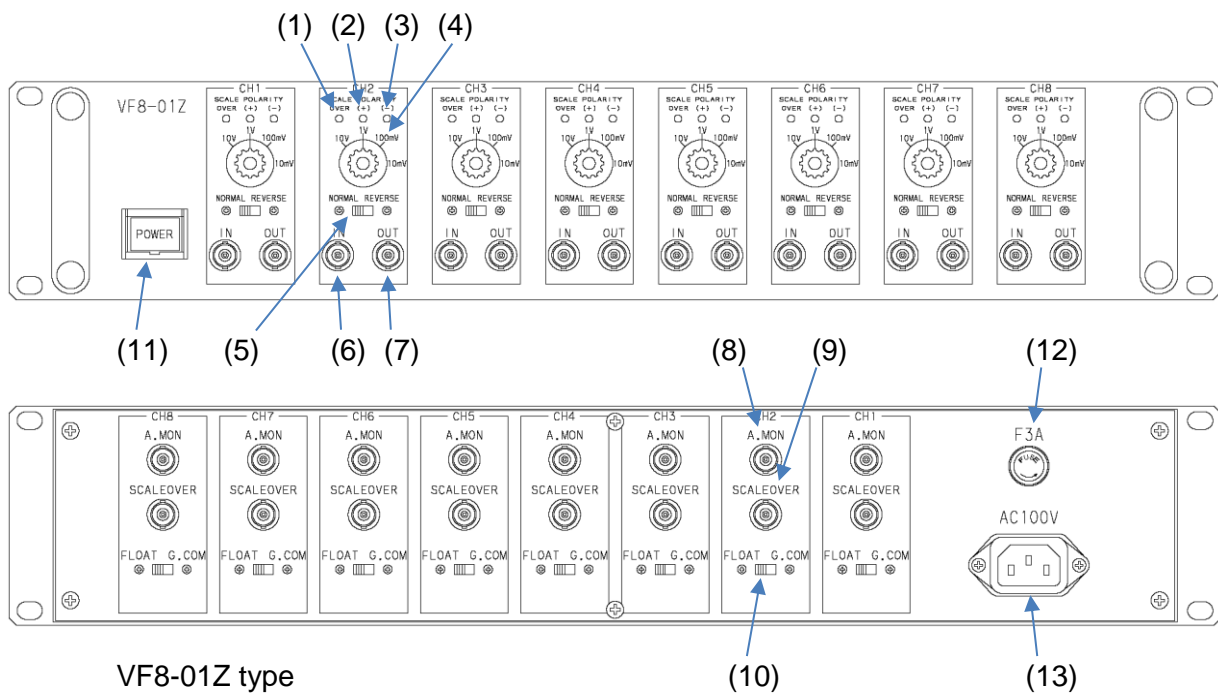

Front Panel

(1) Scale over LED lamp (RED)

LED lights on if the input level exceeds conversion level.

If Scale over LED lights on, the conversion is not done correctly.

(2) Polarity (+) LED lamp (GREEN)

The polarity of the analog signal that is before V-F conversion is (+).

And VF conversion is done correctly.

(3) Polarity (-) LED lamp (RED)

If its LED lights on, the polarity of the analog signal before the VF conversion is negative.

And for correct conversion, the signal polarity must be changed by input polarity selection.

(4) Input range select SW

Select SW in response to the analog value of the input signal.

Input range		Analog input signal
10V	:	0 ~ 10V
1V	:	0 ~ 1V
100mV	:	0 ~ 100mV
10mV	:	0 ~ 10mV

Analog signal can be converted by VF polarity switching of (5), even if input polarity is (-).

(5) Select input polarity

Input polarity (Normal or Reverse) must be selected by the polarity of input signal as follow.

When VF conversion is not working by incorrect input polarity, LED (RED) is lighted on.

Analog input signal		Input polarity selection
0 ~ 10V	:	NORMAL
0 ~ -10V	:	REVERSE

(6) Input BNC connector

Input analog signal of V-F conversion.

Input will be isolated from case GND, if the FLOATING is selected in the switch (10).

(7) Output BNC connector

Output is TTL positive pulse.

The output has been isolated from the internal circuit because there is photocoupler.

(8) Analog monitor BNC connector

Analog value before VF conversion has been output through the buffer.

GND level is the same as analog input (6).

Rear Panel

(9) Scale over output BNC connector

Transistor (open collector) tuens on, if scale over.

Output is isolated.

(10) Floating / Non Floating (G.COMMON) select SW

Selected the below.

Floating : Isolates the input signal's GND and case.

Non Floating : Unites the input signal's GND and case.

Power

(11) Power SW

Power On/Off switch.

LED lights on at power on.

(12) Fuse

There is 3A fuse inside of it.

(13) AC input connector

Inlet type of 3PAC connector.

Must connect AC100V (Line, Neutral, and earth ground).

3. Block Diagram of Input / Output Stage

Analog Input

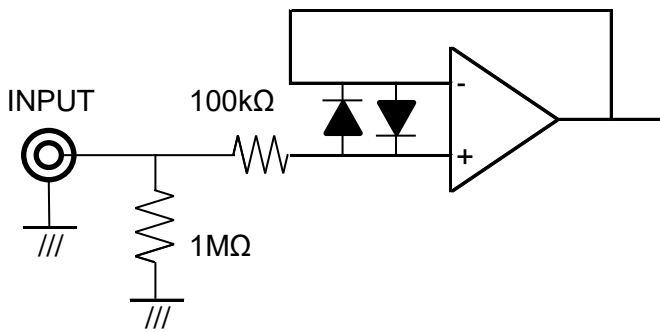

Pulse Output

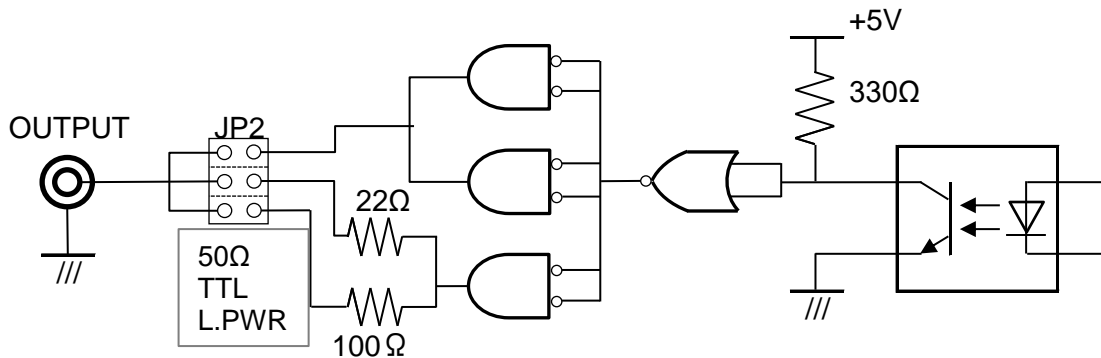

Analog Monitor Output

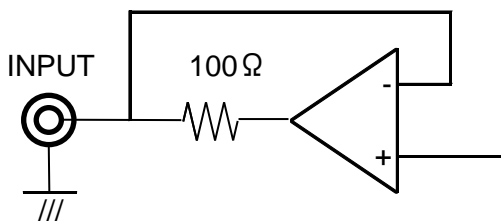

Scale Over Output

